

# Directional Anisotropies Reveal a Functional Segregation of Visual Motion Processing for Perception and Action

Anne K. Churchland,\* Justin L. Gardner,  
I-han Chou, Nicholas J. Priebe,  
and Stephen G. Lisberger  
Howard Hughes Medical Institute  
Department of Physiology  
Neuroscience Graduate Program  
W.M. Keck Foundation Center for  
Integrative Neuroscience and  
Bioengineering Graduate Group  
University of California, San Francisco  
San Francisco, California 94143

## Summary

**Humans exhibit an anisotropy in direction perception: discrimination is superior when motion is around horizontal or vertical rather than diagonal axes. In contrast to the consistent directional anisotropy in perception, we found only small idiosyncratic anisotropies in smooth pursuit eye movements, a motor action requiring accurate discrimination of visual motion direction. Both pursuit and perceptual direction discrimination rely on signals from the middle temporal visual area (MT), yet analysis of multiple measures of MT neuronal responses in the macaque failed to provide evidence of a directional anisotropy. We conclude that MT represents different motion directions uniformly, and subsequent processing creates a directional anisotropy in pathways unique to perception. Our data support the hypothesis that, at least for visual motion, perception and action are guided by inputs from separate sensory streams. The directional anisotropy of perception appears to originate after the two streams have segregated and downstream from area MT.**

## Introduction

The primate brain contains a multiplicity of distinct visual areas that can be distinguished based on anatomy, connectivity, visual topography, and selectivity for visual stimuli (Felleman and Van Essen, 1991; Zeki, 1978). It is commonly accepted that there is a hierarchical organization of areas for visual processing but that signals also diverge, forming separate functional pathways: one passing through parietal cortex and one through temporal cortex (Ungerleider and Mishkin in Ingle et al., 1982). Although the functional segregation is not likely to be absolute, one view is that these two streams mediate different visual functions, namely, spatial versus object vision. An alternative view is that, rather than different visual functions, the two streams underlie different usages of visual information, with the dorsal stream processing visual information for movement or action and the ventral stream processing visual information for perception (Goodale and Milner, 1992).

Both views arose from observations of human pa-

tients with different, specific cortical lesions and separable deficits in the use of visual inputs. Patients with damage in the dorsal stream of visual processing experience difficulty reaching for visual targets that they can identify with ease (Perenin and Vighetto, 1988). Patients with damage in the ventral stream of visual processing show deficits in recognition of objects that they can skillfully manipulate by orienting their hands in the correct position (Farah et al., 1990; Goodale et al., 1991; Milner et al., 1991). Certainly visual signals for perception and action must arise from a common origin, the retina, and ultimately become separate at some point in the brain, as actions and reports of perceptual sensation can require different end effectors. Our goal was to place constraints on the site of separation, by comparing performance on perception and action tasks involving a visual function that is comparatively well understood at psychophysical, behavioral, and neural levels: processing of the direction of visual motion.

We took advantage of a well-documented finding that normal humans have reliable anisotropies in perceptual performance for direction discrimination: thresholds for discriminating the direction of visual motion are lower when the motion is centered around cardinal (horizontal and vertical) axes than around diagonal axes (Ball and Sekuler, 1980; Gros et al., 1998). We ask whether the same anisotropy is evident in motor tasks by analyzing the initiation phase of smooth pursuit eye movements (Keller and Heinen, 1991; Lisberger et al., 1987) to motion along different axes. We observed an anisotropy in perception and not in pursuit, showing that processing for pursuit and perception indeed becomes segregated. To further constrain the anatomical locus of the anisotropy for perception, we searched for a directional anisotropy in a large sample of recordings from neurons in the middle temporal visual area (MT) of monkeys. Because both pursuit and perception rely on motion-sensitive neurons in MT (Komatsu and Wurtz, 1988; Komatsu and Wurtz, 1989; Newsome and Pare, 1988; Salzman et al., 1990, 1992), streams of processing for our perceptual and pursuit task are unlikely to diverge before MT. Our analysis here did not reveal biases within MT responses that might support the directional anisotropy of perception. Taken together, our behavioral and neural evidence are consistent with the idea that perception and action are guided by inputs from separate sensory streams. In the visual motion system, the streams seem to separate downstream from area MT, and the directional anisotropy of perception appears to originate after the point of separation.

## Results

### Directional Anisotropy of Perception

First, we tested subjects' perceptual discrimination of target directions using motion stimuli similar to those in our subsequent pursuit task. Human subjects viewed two brief target motions in succession and reported whether they were in the same or different directions by pressing

\*Correspondence: anja@phy.ucsf.edu

A Example "same" trials

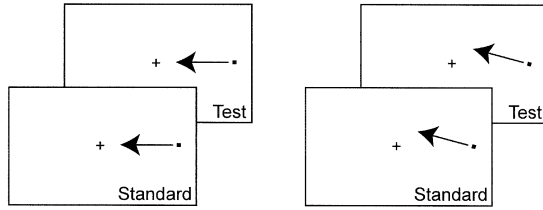

B Example "different" trials

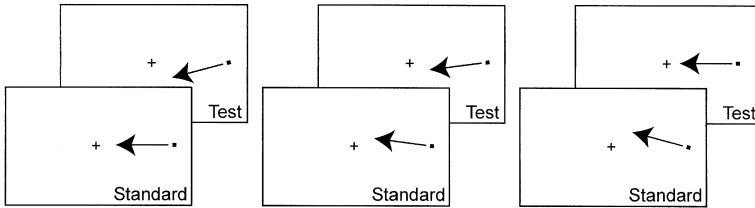

ceptual separation was achieved using three additional configurations (data not shown) where trajectories were presented in the reverse order of what is presented. Note that the deviation from purely horizontal was exaggerated in this figure to be clearly visible. For real tests of perceptual discriminability, trials around the horizontal axis were never more than 2° off purely horizontal.

one of two buttons. Targets consisted of small spots moving along or very close to the horizontal, vertical, or diagonal axes, as shown in Figure 1. The small difference between the directions of the two target motions will be called the "perceptual separation." We initially used a staircase procedure to find each subject's direction discrimination threshold and tailored perceptual separations of target direction that were just above threshold for each subject (3.5°, 2.5°, 2.5°, and 1.5° for subjects JG, AC, RR, and MB, respectively). Proper selection of perceptual separations gave rise to high enough hit and false alarm rates to calculate  $D'$ , a measure of discriminability that is not subject to response biases (Green and Swets, 1966).

Each subject exhibited better perceptual direction discrimination (indicated by larger values of  $D'$ ) for target motion along cardinal axes than along the diagonal axis (Figure 2), confirming that our stimuli give rise to the same anisotropy found in earlier studies (Ball and Sekuler, 1980; Gros et al., 1998; Heeley and Buchanan-Smith, 1992). To quantify the degree of anisotropy present in these data, we calculated an anisotropy index (Experimental Procedures) which is 0 for perfectly isotropic and 1 for perfectly anisotropic perceptual direction discrimination. In our four subjects, the value of the anisotropy index ranged from 0.29 to 0.40. The mean was 0.33 and was significantly different from 0 (Student's  $t$  test,  $p < 0.005$ ).

**Absence of a Directional Anisotropy for Pursuit**

Subjects were instructed to track small spots moving in directions that were horizontal, vertical, or diagonal, or were very close to these axes. Traces from an example experiment are shown in Figures 3A–3C. Two sets of pursuit trials were collected, one in which the target started at the right of the fixation point and moved horizontally at 25°/s to the left (black arrow and traces, Figures 3A and 3B) and another in which the target started from the same point and moved with the same

Figure 1. Examples of Target Trajectories Used to Determine How Well Direction Could Be Discriminated when Motion Was Centered around the Horizontal Axis

(A) Two pairs of standard and test trajectories in the same direction (a perceptual separation of 0°). Left pair: two identical trajectories, each purely horizontal. Right pair: two identical trajectories, each slightly above the horizontal. The same 0° perceptual separation was achieved using one additional configuration (data not shown) where the standard and test trajectories were both 3° below horizontal. (B) Three pairs of standard and test trajectories in slightly different directions. In each case, the perceptual separation is 3°. Left pair: standard trial is purely horizontal, test trial is 3° below the horizontal. Middle pair: standard trial is 1.5° above the horizontal and test trial is 1.5° below the horizontal. Right pair: standard trial is 3° above the horizontal, test trial is purely horizontal. The same 3° per-

speed but in a direction 5° above horizontal (gray arrow and traces, Figures 3A and 3B), i.e., to the left and slightly upward. The difference in the directions of the two sets of target motions will be called the "pursuit separation." Comparison of eye velocity responses for two motions near the horizontal axis (Figure 3C) reveals that the 2.18°/s difference in vertical target velocity causes a clear difference in vertical eye velocity that develops gradually over the first 200 ms of the response.

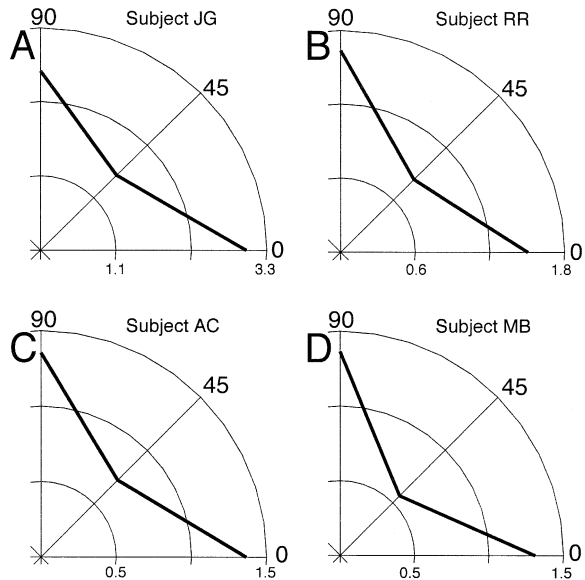

Figure 2. Polar Plots Describing Perceptual Discrimination as a Function of Direction for Each of the Four Subjects

Each plot uses line segments to connect the measurements of  $D'$  made for target motion centered around the 0°, 45°, and 90° axes. Each of the three measurements represents the end of a vector with length  $D'$  starting from the point of intersection of the three axes. In (A)–(D), the difference between standard and test trajectories on "different" trials was 3.5°, 2.5°, 2.5°, and 1.5°.

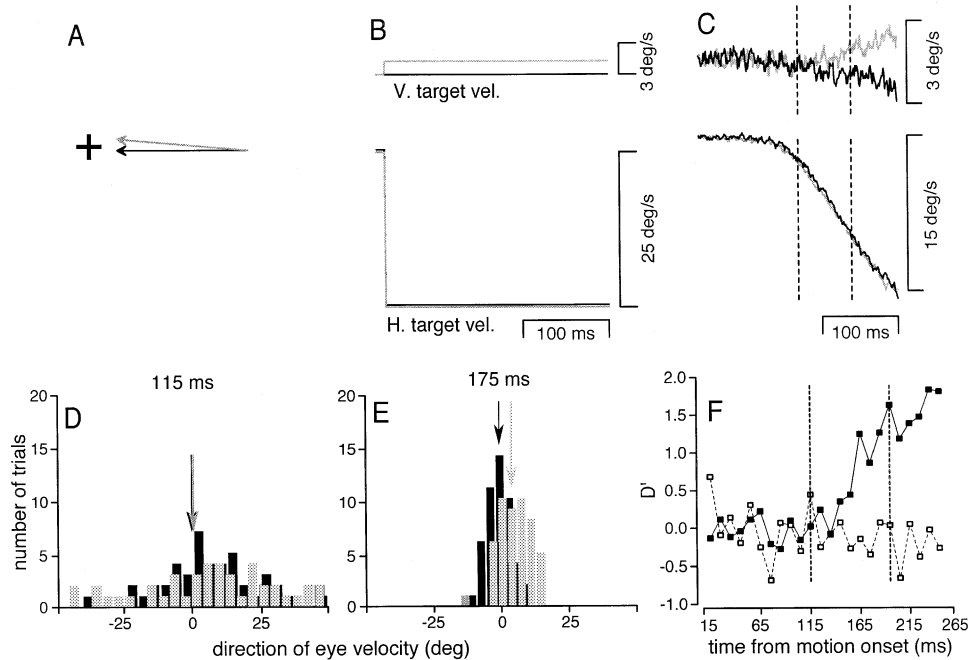

Figure 3. Examples of Target Motion and Responses Used to Test Direction Discrimination for Pursuit

- (A) The vectors indicate the target direction for two targets that moved either leftward or  $5^\circ$  up from leftward.  
 (B) Horizontal and vertical target velocity. Note that the two horizontal traces are slightly offset to facilitate viewing.  
 (C) The upper and lower pairs of traces show median horizontal and vertical eye velocity: downward deflections indicate leftward or downward motion. The black and gray traces show responses to motion that was purely horizontal ( $n = 48$ ) or  $5^\circ$  up from horizontal ( $n = 49$ ). Forty-eight and 49 trials were used to compute median eye velocities for the purely horizontal and the  $5^\circ$  trajectories, respectively.  
 (D and E) Distributions of response directions for all trials measured in intervals centered around 115 and 175 ms after the onset of target motion. Gray bars indicate responses to purely horizontal motion, while black bars indicate responses to motion that was  $5^\circ$  up from horizontal. The arrows indicate the means for each distribution.  
 (F)  $D'$  for pursuit is plotted as a function of time from the onset of target motion. Data were averaged in 10 ms bins, and  $D'$  was measured at each time point. Points on the x axis indicate the center of the time bins. The solid line with solid squares indicates  $D'$  values estimating the discriminability of responses to two different target trajectories. The dashed line with open squares describes  $D'$  values estimating discriminability of responses to the same target trajectory (see Experimental Procedures) as an estimate of noise. Vertical dashed lines indicate the time interval from 110 to 200 ms, which we considered to be open-loop pursuit.

The effect of target direction on the direction of pursuit evolves over the first 90 ms period of pursuit (Experimental Procedures, dotted lines in Figure 3C), which comprises the response before there has been time for visual feedback and is called the “open-loop” response (Lisberger and Westbrook, 1985; Morris and Lisberger, 1987). To quantify how well pursuit responses can discriminate similar target trajectories, we performed an analysis of subjects’ pursuit trajectories during the open-loop response. The analysis was based on signal detection theory and is illustrated in the bottom row of Figure 3.

Early on, pursuit direction does not reflect the direction of the targets accurately: distributions of eye velocity direction evoked by target motion in directions  $0^\circ$  (black bars, Figures 3D and 3E) and  $5^\circ$  (gray bars, Figures 3D and 3E) exhibit a broad distribution whose means are not significantly different (difference of means =  $0.63^\circ$ ,  $p = 0.49$ , Student’s *t* test, gray and black arrows Figure 3D). Sixty milliseconds later, toward the end of the open-loop response of pursuit, eye velocity discriminated target direction better: eye velocity directions are more tightly distributed, forming two distributions whose means are significantly different (difference of

means =  $4.5^\circ$ ,  $p < 0.001$ , Student’s *t* test, gray and black arrows, Figure 3E). For the distributions in Figures 3D and 3E,  $D'$  was 0.006 and 0.844, respectively. Calculating  $D'$  in 5 ms bins (solid black trace in Figure 3F) shows that pursuit begins with  $D'$  near 0 and rises steadily to reach a value greater than 1.5 before the end of the open-loop response. A comparison of the true  $D'$  values (solid black trace) and those generated using a bootstrapping method to estimate the noise (thin dashed trace, see Experimental Procedures) reveals that the  $D'$  values at the end of the open-loop response are larger than one would expect from random fluctuations of eye velocity.

One fundamental problem in comparing pursuit to perception is that perceptual judgments can be made according to motion information garnered throughout the trial, while pursuit responses are continuous movements that develop over time. There exists no single moment of the pursuit response that is necessarily comparable to the time of perceptual judgment. To ensure that our comparison of pursuit and perception would not be affected by the time period chosen to analyze pursuit, we used three methods to weight the values of  $D'$  obtained during different intervals of the open-loop

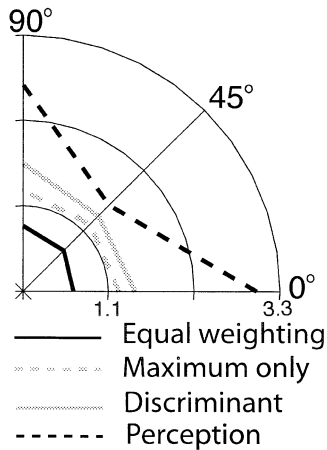

Figure 4. Polar Plot Comparing the Perceptual Anisotropy with the Absence of a Pursuit Anisotropy in Subject JG

Each of the four sets of line segments connects the endpoints of vectors that plot  $D'$  for target motion centered along different axes. The black dashed trace shows  $D'$  values for perception. The other traces show  $D'$  values for pursuit using the three different analysis methods. Black solid trace, equal-weighting analysis; gray dashed trace, maximum-only analysis; gray solid trace, discriminant analysis.

pursuit response. Figure 4 shows that we found a similar lack of anisotropy in pursuit direction discrimination regardless of whether the analysis weighted the nine 10 ms intervals equally by averaging (black solid trace, Figure 4), used only the maximum value of  $D'$  (gray dashed trace, Figure 4), or used a discriminant analysis that weighted the values of  $D'$  according to the difference in the mean eye velocity directions (gray solid trace, Figure 4). Importantly, the values of  $D'$  generated by averaging were almost never 0, even for the smallest separation tested (mean value across subjects = 0.2311 for small separations and 0.6141 for large separations). The distribution of responses was significantly greater than 0 for both separations (small,  $p < 0.04$ ; large,  $p < 0.001$ ). As expected, the bootstrapped values of  $D'$  were neither large nor consistently positive and did not differ significantly from 0 ( $p = 0.5$ ), ensuring that values of  $D'$  reflected real differences in subjects' responses to the two trajectories rather than noise in the eye velocity trace.

Since the three different methods used to calculate discriminability of pursuit yielded comparable results, we show data for all subjects using the discriminant analysis. Comparison of the patterns of discriminability reveals that, in general, pursuit (Figure 5, gray traces) did not display the same anisotropy as perception (Figure 5, black traces). While perceptual discriminability for all subjects was poorest for target motion along the  $45^\circ$  axis, the axis of the poorest discrimination for pursuit varied idiosyncratically among subjects. We show values of  $D'$  for targets of two different pursuit separations for each subject. One separation was the same as or as close as possible (Experimental Procedures) to that used to measure the perceptual anisotropy (dashed gray trace), and one was slightly larger (solid gray trace). With one exception (MB), the pattern of pursuit discriminability was the same at the different pursuit separations,

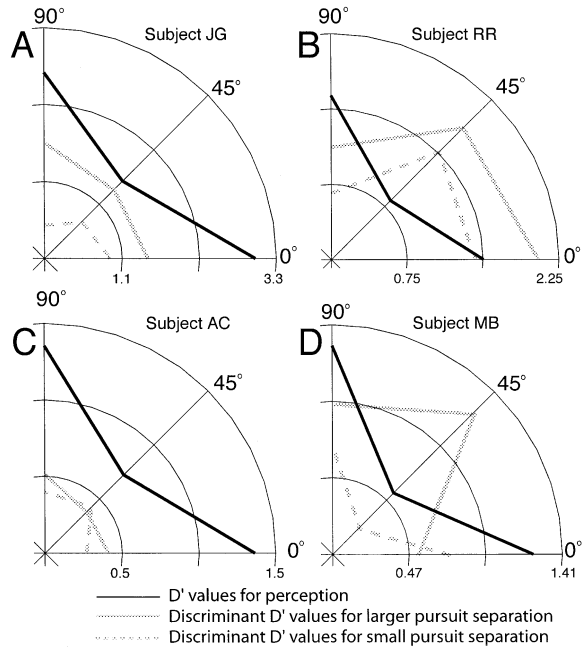

Figure 5. Polar Plots Comparing the Perceptual Anisotropy with the Absence of a Pursuit Anisotropy in Each Subject

In each panel, the three sets of line segments connect the endpoints of vectors that plot  $D'$  for target motion centered along different axes. Solid black traces indicate the values of the  $D'$  for perception, as shown in Figure 2. Gray traces indicate values of the  $D'$  for pursuit, obtained using the discriminant analysis. The dashed gray trace corresponds to data obtained with the pursuit separation that was the same as (subjects JG and AC) or very close to (subjects MB and RR) the perceptual separation. The solid gray trace corresponds to the pursuit separation that was larger than the perceptual separation.

- (A) Pursuit separations were  $3.5^\circ$  and  $5^\circ$ .
- (B) Pursuit separations were  $2.5^\circ$  and  $5^\circ$ .
- (C) Pursuit separations were  $3^\circ$  and  $5^\circ$ .
- (D) Pursuit separations were  $3^\circ$  and  $6^\circ$ .

providing reassurance that our analysis estimates the true discriminability along different axes and does not simply reflect erratic variation in pursuit responses.

Comparison of pursuit and perceptual anisotropy indices (Figure 6) shows that the perceptual indices cluster near 0.33, while the pursuit indices cluster around 0. Because each subject was tested at two pursuit separations and only one perceptual separation, each anisotropy index for perception is paired with two anisotropy indices for pursuit, one circle (small separation) and one cross (larger separation). The results were generally similar for the three different analysis methods used for pursuit and for both pursuit separations in each subject, shown by the overlap between the distributions of crosses and circles. In each graph, the one case where the anisotropy index was considerably larger for pursuit than for perception was from subject MB for pursuit targets separated by  $3^\circ$ .

Across all subjects, the anisotropy index for pursuit did not depend strongly on which of the three analysis methods was used to estimate it and was generally smaller for pursuit than for perception. A Student's two-tailed t test revealed that the group's average anisotropy

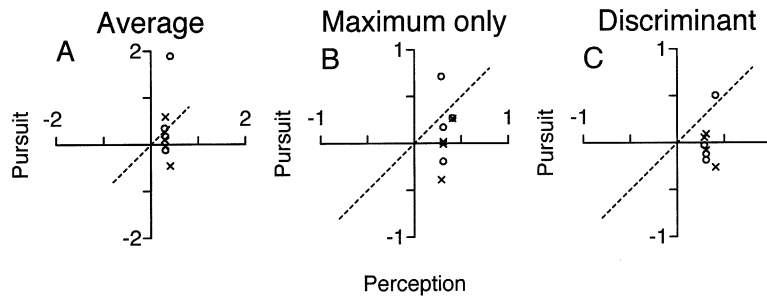

Figure 6. Quantitative Comparison of Anisotropy Indices for Pursuit and Perception  
Each graph plots data obtained using a different method to analyze the direction discrimination for pursuit.

(A) Equal-weighting analysis. Note that larger axes are used because of one outlier with a large value.

(B) Maximum-only analysis.

(C) Discriminant analysis.

Because  $D'$  was measured at two separations for pursuit and only one separation for perception, each subject provided two points in

each graph. They plot at the same values of anisotropy index for perception, where the circle indicates data obtained with the pursuit directional separation most similar to that used for perception, and the cross indicates a larger directional separation.

index for pursuit was not significantly different from zero for any of the three analysis procedures (equal weighting: mean =  $-0.0016$ ,  $p = 0.99$ ; discriminant: mean =  $-0.002$ ,  $p = 0.99$ ; maximum only: mean =  $0.11$ ,  $p = 0.39$ ). A value of 0 indicates that responses are not directionally anisotropic. Group averages for the anisotropy index were, again, not significantly different from zero when small and large separations were analyzed separately.

#### Absence of a Directional Anisotropy in Responses of MT Neurons

To test directly whether the neural basis for the perceptual anisotropy lies downstream from MT, we analyzed the responses of a large population of neurons recorded from area MT in anaesthetized macaque monkeys. We used stimuli well-suited for MT neurons to look for neural anisotropies that could have supported the perceptual anisotropy in five different aspects of the responses of MT neurons.

#### Preferred Directions

In agreement with prior studies (Albright, 1984; Kiropes et al., 1996; Maunsell and Van Essen, 1983), our sample of MT neurons did not exhibit a skewed distribution of preferred directions (Figure 7A, left panel). A Rayleigh's test revealed that the distribution of responses was not significantly different from random ( $p = 0.28$ ). Counting the number of cells that had preferred directions within  $5^\circ$  of cardinal or diagonal axes also failed to reveal any emphasis of cardinal axes (Figure 7A, right panel): 25 neurons preferred cardinal directions, and 25 neurons preferred diagonal directions. When this analysis was performed on individual monkeys, 5 of 11 animals exhibited distributions of preferred directions that were significantly skewed ( $p < 0.05$  according to a Rayleigh's test). However, the skew was not consistent across monkeys; skews were centered around  $63^\circ$ ,  $94^\circ$ ,  $332^\circ$ ,  $152^\circ$ , and  $88^\circ$  for the five monkeys showing significant skew. It seems likely that the skew in these five monkeys results from having sampled only limited regions of MT in each individual monkey.

#### Tuning Width

We measured the angular variance of each neuron's responses. Angular variance does not describe variability in firing rates but rather how the response varies across the eight directions measured. The distribution of angular variance as a function of preferred direction (left panel of Figure 7B) was not significantly different

from random (Hotelling's  $T^2$  test,  $CI = 0.95$ ). The average angular variance for cells with preferred directions within  $5^\circ$  of the cardinal directions was slightly larger than that for cells preferring diagonal directions. The difference was not significant ( $51.3$  versus  $44.9$  deg, Student's  $t$  test,  $p = 0.38$ ) and was in the wrong direction to support a finer representation of direction by neurons preferring cardinal directions.

#### Peak Firing Rate

Figure 7C shows that neurons preferring cardinal and diagonal directions did not differ in their peak firing rates. The distribution of responses was not significantly different from random (Hotelling's  $T^2$  test,  $CI = 0.99$ ), and the mean responses for neurons with preferred directions near cardinal and diagonal axes were not significantly different ( $31.0$  versus  $26.8$  spikes/s,  $p = 0.48$ ).

#### Firing Rate Variability

Figure 7D shows that distribution of fano factors (variance divided by mean) did not differ significantly from random (Hotelling's  $T^2$  test,  $CI = 0.95$ ). Fano factors for neurons preferring cardinal and diagonal directions were not significantly different ( $1.03$  versus  $1.07$ ,  $p = 0.47$ ).

#### Slope of Tuning Curves

To evaluate the steepness of slopes of MT neurons, we measured the derivative of fitted tuning curves for each neuron at 16 directions equally spaced around  $360^\circ$  and then averaged across cells. Figure 7E shows that distribution of the slopes of tuning curves was not skewed (Hotelling's  $T^2$  test,  $CI = 0.99$ ). Further, cells preferring cardinal and diagonal directions had identical slopes on average ( $0.03$  for both).

#### Discussion

Our data argue that visual motion information for perception and pursuit becomes segregated into separate streams at a locus downstream from area MT. The basis for our conclusion is that smooth pursuit responses do not display the same, consistent directional anisotropy found by ourselves and others (Ball and Sekuler, 1980; Gros et al., 1998; Heeley and Buchanan-Smith, 1992) in the perception of the direction of motion. There is abundant reason to think that both of these systems derive visual motion information from area MT (Britten et al., 1996; Newsome and Pare, 1988; Newsome et al., 1985). Yet, neither pursuit responses nor MT neurons display a consistent directional anisotropy, while perception does. The perceptual anisotropy must, there-

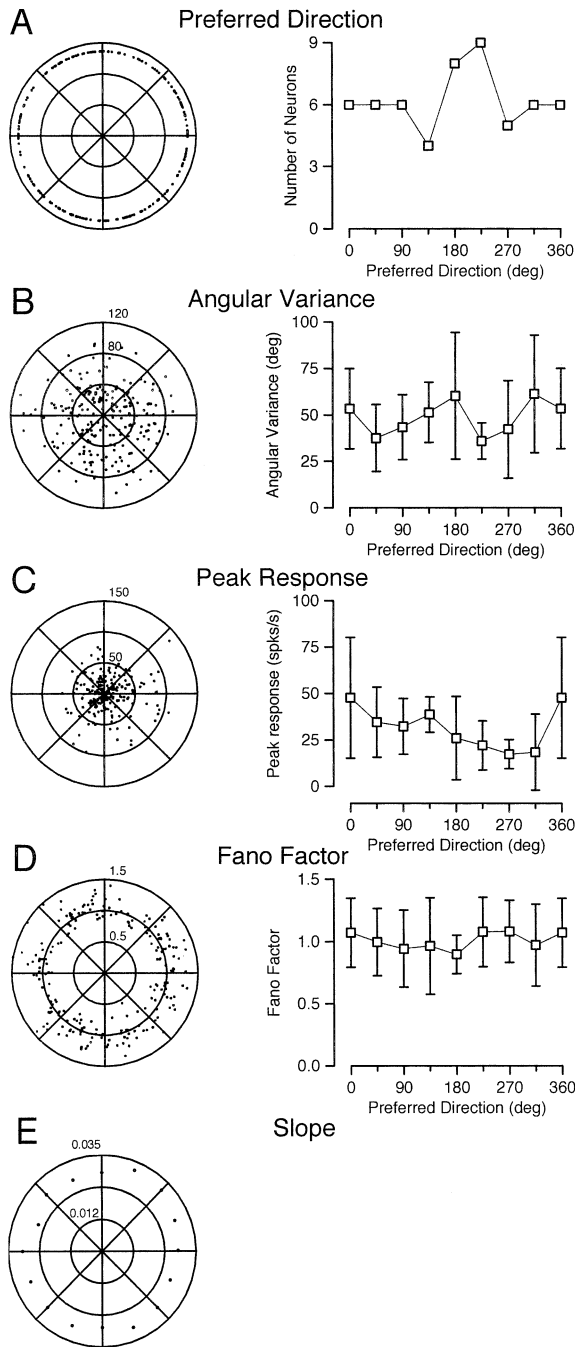

Figure 7. Absence of a Neural Correlate of the Perceptual Anisotropy in the Discharge of a Population of 220 MT Neurons

- (A) Preferred direction.
- (B) Angular variance as a measure of tuning width.
- (C) Response amplitude.
- (D) Fano factor as a measure of firing rate variability.
- (E) Slope of direction tuning curve.

In (A), the left-hand polar plot shows the distribution of preferred directions in our sample with all points plotted the same distance from the origin. In (B)–(D), the left-hand polar plots show the distribution of three additional parameters of the neural responses, where each point is the end of a vector that represents the responses of one neuron and plots the value of one response parameter as the distance from the origin and the preferred direction of the neuron as the angle. In (E), the polar plot summarizes the average slopes of the direction tuning curves measured in all neurons for eight

fore, arise in circuits that are not shared with pursuit and that are downstream from, or parallel to, area MT.

To address the hypothesis that perception and action use separate sensory streams, it was necessary to start by replicating and extending earlier findings of directional anisotropies of perception. This allowed us to verify that the perceptual anisotropy persists when using targets that are suitable for our pursuit experiment and are presented only briefly. Furthermore, using  $D'$  for quantification shows that the perceptual anisotropy is not due to response bias, a more cognitive factor that would not be expected to arise from visual motion processing. Last, demonstrating the perceptual anisotropy in our subjects allowed direct within-subject comparison with the results of similar experiments on pursuit.

### Issues in Comparing Direction Discrimination of Pursuit and Perception

We start by considering several features of our approach that lend strength to our comparison of the sensory processing for perception and action.

First, our main conclusions have come from looking at patterns of direction discrimination within pursuit and within perception. The observation of different patterns within pursuit and within perception gives stronger evidence of a genuine difference than would an approach that compared across response modalities. It is tempting to directly compare the values of  $D'$  calculated for perceptual reports and those for pursuit, but differences in the methodologies used to analyze discriminability for pursuit and perception would give rise to uncertainties in the absolute value of  $D'$  calculated for the two behaviors. This problem is obviated by calculation of the anisotropy index, because it compares the pattern of  $D'$  values within each single response modality while varying only the direction of the base target motion.

Second, our stimulus presentation considers the different time scales over which perceptual decisions and pursuit eye movements could sample the sensory stimulus. In the perceptual task, we allowed subjects to view the moving target only briefly. In the pursuit task, we analyzed only the first 90 ms of the response, reflecting the response to target motion of the same duration used to study perception.

Third, we used analyses for the pursuit data that modeled different ways that the perceptual system might sample visual motion while viewing a stimulus over time: averaging over time points, considering only the time point where the representations of stimuli are most different, and weighting time points according to how different they are. Importantly, the conclusions about pursuit discriminability do not depend on the analysis procedure: we did not see a consistent anisotropy in pursuit for any of the three analyses we used. The combined use of

different directions of stimulus motion. One point was not included in the polar plot in (B) and four points were not included in (D) so that the scales would be appropriate for the remaining 219 or 216 points. In (A)–(D), the right-hand graph summarizes the relationship between the response parameter and preferred direction, where each point is the average for neurons with preferred directions within  $5^\circ$  of the value on the abscissa.

three analysis methods provides some assurance that anisotropies would have been uncovered if they were present in pursuit. Although subjects exhibited idiosyncratic pursuit anisotropies, the three methods of analysis were generally in good agreement (values of the anisotropy index were never significantly different from zero for any analysis method). For one subject at one separation (MB, 3°), pursuit responses exhibited the same anisotropy as perception. However, other anisotropies were also observed: subject JG's pursuit for a pursuit separation of 3° discriminated near-horizontal trajectories poorly, while subject RR's pursuit for 3° discriminated near-vertical trajectories poorly. Pursuit and perception differed in that the anisotropies for perception consistently favored cardinal directions of motion, while those for pursuit were idiosyncratic. We observed the most variability for the smallest pursuit separations tested: those that were most similar to the perceptual separations we used. Other work (Watamaniuk and Heinen, 1999) has also suggested that discriminability at a given separation can be noisier for pursuit than for perception.

#### **The Neural Basis for the Perceptual Anisotropy**

Our finding that pursuit eye movements do not share the directional anisotropy of perception provides behavioral evidence that the circuitry underlying pursuit diverges at some point from the circuitry underlying a perceptual report. To begin to localize the point of divergence, we analyzed data recorded from MT of monkeys. We would have liked to relate physiology to behavior in the same species; however, there are a number of reasons to believe that the motion processing in the brain is similar in these two species. Monkeys and humans exhibit similar performance on direction discrimination tasks (Huk et al., 2002; Newsome and Pare, 1988), their pursuit is similarly affected by a host of stimulus manipulations (Churchland and Lisberger, 2002, Lisberger et al., 1981), and they appear to contain similarly organized motion processing regions (Huk et al., 2002). Thus, our failure to find a neural correlate of the anisotropy in the responses of MT neurons in the monkey suggests that the site of the divergence of processing for perception and pursuit is downstream from area MT. Kiorpes et al. (1996) found a similar mismatch of an anisotropy in pursuit and the lack of a neural correlate of MT in monkeys with early-onset strabismus. They also concluded that the site of the anisotropy was downstream from MT but, in their case, in the circuitry that generates pursuit. Kiorpes et al. also observed, as we did, that direction preferences in MT of individual monkeys are sometimes anisotropic. Because these anisotropies vary from monkey to monkey, data combined across a population is almost perfectly isotropic. Individual anisotropies in MT could explain the idiosyncratic anisotropies that we observed in human pursuit responses. However, variability downstream from area MT might also contribute to the idiosyncratic anisotropies that we observed in pursuit.

Goodale and Milner's (1992) hypothesis that the primate visual cortex contains distinct streams for perception and action has inspired numerous experimental attempts to dissociate the two streams. Lesion studies in animals and humans have revealed that one class of

functions can be impaired while the other is spared (Aggleton and Mishkin, 1983; Weiskrantz and Saunders, 1984). However, interpreting lesion data can be complicated, particularly with human patients whose damage may be incomplete or includes more than one area. The lesion data has been supplemented by a large body of behavioral studies in which a subject's perceptual report was compared with the same subject's motor output. A common strategy is to bias the subject's perception in some way and ask whether a motor output is similarly biased. For example, multiple studies have compared subjects' verbal report of object size with subjects' grasp aperture when they reached for the object (for review, see Bruno, 2001; Dyde and Milner, 2002; Franz, 2001). Dyde and Milner (2002) provide evidence for the segregation of perception and action using two stimulus manipulations known to bias processing in early and late cortical areas. This task configuration allowed them to put forth, as we have, a putative site of segregation for perception and action. However, the conclusions from many other behavioral experiments have not consistently supported the hypothesis of Goodale and Milner (1992). Some reported that actions resisted perceptual illusions, while others argued that perception and action changed together. These studies are particularly hard to interpret when the stimulus manipulations involve visual illusions whose neural basis is not known. Furthermore, the visual inputs to the circuitry involved in grasp movements are incompletely understood.

The visual inputs to the oculomotor system are understood in more detail, and the motor outputs are straightforward to measure accurately (for review, see Kaminski and Leigh, 2002). Eye movements therefore provide a good model system in which to search for dissociations between perception and action. Again, however, experimental results have provided evidence both for and against a dissociation between perception and action. Distortions of visual space around the time of a saccade have been shown to be present in subjects' verbal reports but not in their pointing movements or in the accuracy of their saccades (Burr et al., 2001; Hallett and Lightstone, 1976). Importantly, perception and action were dissociated only when subjects were tested in the dark to prevent visual feedback from affecting pointing (Burr et al., 2001). This underscores the importance of measuring movements that are unaffected by visual feedback, as we have done. Use of an experimental design that allowed visual feedback may explain why Kowler and McKee (1987) found that pursuit and perception had similar thresholds for discriminating the speed of two targets. Unlike our study, Kowler and McKee (1987) examined motor responses late in each pursuit trial, after visual feedback had been able to establish excellent steady-state behavior.

Other experiments comparing pursuit and perception (Beutter and Stone, 1998; Krauzlis and Adler, 2001) found illusions that biased both response modalities equally. A variety of specifics of the experimental design could explain the differences between their results and ours. First, both Beutter and Stone (1998) and Krauzlis and Adler (2001) used stimuli that biased or shifted a subject's perception and showed that the same bias or shift was present in pursuit. We used stimuli that revealed asymmetries in the precision of the perceptual

report without shifting it. Second, our perceptual task required subjects to remember a standard for comparison, whereas the tasks used by Beutter and Stone (1998) and Krauzlis and Adler (2001) did not. Thus, our perceptual task required the use of working memory, while the pursuit task did not.

We suggest a more fundamental reason why there have been so many conflicting reports on whether divergent pathways underlie perception and action. There is little doubt that some visual circuitry must be shared by both perception and action. Thus, there must be a site where the processing for perception and action diverges into separate circuits. Viewed in this light, conflicts in the experimental literature are expected. Stimulus manipulations that affect responses in shared visual areas are likely to have the same effect on both perceptions and actions. Stimulus manipulations that affect responses after the separation of processing will have different effects on perception and action. If many different stimulus manipulations are tried, some will affect processing before and some after the circuits for perception and action separate. Accordingly, some will affect perception and action equally, and some will not. The question is perhaps not whether the circuits for sensation and action diverge, but where the divergence occurs for specific perceptions and actions. Our experimental approach starts to address this latter question by using behaviors with fairly well understood neural circuits so that interpretation of the data is easier. Further, by combining physiology with behavior we have begun to localize the site of divergence for the circuits that mediate perceptions and actions that arise from visual motion.

## Experimental Procedures

### Human Subjects

Subjects were scientists and students from the Keck Center for Integrative Neuroscience at the University of California, San Francisco, or members of the surrounding community. Four subjects, one female and three male, were tested. Subjects gave their informed consent at the beginning of each experiment. Subject MB was completely naïve, subject RR had some previous experience as a subject in eye movement experiments but was naïve to the specific hypothesis being tested, and subjects JG and AC were authors. Experiments were performed over a 3 hr period that included some breaks between blocks. Most subjects completed the experiment in 1 day; occasionally, subjects returned the next day to complete testing. All subjects were healthy and had normal vision. Experimental procedures were approved in advance by the Committee on Human Research, which is the Institutional Review Board for UCSF and its affiliates.

### Eye Movement Recording

Two-dimensional movements of the right eye were measured using the Fourward Technologies Dual Purkinje Image Tracker (Generation 6.1). Subjects' heads were stabilized using a chin rest and a head strap that subjects adjusted to be snug but comfortable. The tracker's automatic moveable optical stage (auto stage) and focus servo were both disabled to avoid introducing head position artifacts into the eye position signal.

Signals related to horizontal eye velocity, eye position, and target position were digitized during the experiment at a sampling rate of 1000 samples/s. The eye position signal was low-pass filtered with a cutoff at 330 Hz and voltages proportional to eye velocity were obtained by differentiating the eye position signals with an analog circuit (DC to 25 Hz, -3 dB).

### Visual Stimuli

Visual stimuli were projected onto the back of a tangent screen that was 40 cm from the subject and subtended a visual angle of 32° by 26°. The image from a red LED provided a circular, 0.1° stationary fixation target (0.2 cd/m<sup>2</sup>). Circular 0.5° pursuit targets (3.5 cd/m<sup>2</sup>) were created by reflecting the beam from a fiber-optic light source off an orthogonally placed x-y pair of mirror galvanometers. The galvanometers were driven by the digital-to-analog outputs from a Pentium PC computer. The experimental room was kept quite dark, as the tracker works best when the pupil is dilated.

Trials used to estimate the discriminability of perception consisted of two brief trajectories of target motion. Subjects were instructed to fixate on a red spot at the center of the screen throughout the trial. Eye movements were monitored in initial experiments to verify that fixation was maintained. After 1000–1200 ms of fixation, the first white target (the “standard”) appeared 3° eccentrically to the right (0°), above (90°), or obliquely displaced from the fixation target (45°) in different trials. The target immediately began moving at 25°/s either directly or almost directly toward the fixation point for 72–88 ms and was then extinguished so that only the red LED remained. Five hundred ms later, a second white target (the “test”) appeared at the same location as the first and immediately moved at 25°/s in either an identical or slightly different direction as the first target for 72–88 ms. All targets were then extinguished. During the subsequent 1250 ms, subjects pressed one of two buttons to report whether they judged the standard and test trajectory to be the same or different. Correct responses were categorized as either hits (the two trajectories were different, and the subject reported that they were different) or correct rejects (the two trajectories were the same, and the subject reported that they were the same). Incorrect responses were categorized as either false alarms (the two trajectories were the same, but the subject incorrectly reported that they were different) or misses (the two trajectories were different, but the subject incorrectly reported that they were the same).  $D'$  values were calculated as the difference between hit and false alarm z-scores (Green and Swets, 1966) and were then scaled to reflect that they were generated in a same-different rather than a yes-no paradigm (Macmillan and Creelman, 1991). Subjects were given feedback about the correctness of their responses during initial training but not during testing.

To be sure that subjects employed velocity cues, two features of our stimulus presentation were designed to prevent subjects from using endpoint positions of trajectories to make judgments. (1) The duration of each trajectory was randomized so that targets of identical directions ended in different places. (2) Multiple target trajectories were used for both “same” and “different” trials (Figure 1). The difference between standard and test trials, called the “perceptual separation,” was 0° in all the “same” trials described (Figure 1A). However, the endpoints of the “same” trajectories differed across trials. A horizontal “different” trial with a 3° separation could consist of several distinct pairs of trajectories with unique target endpoints (Figure 1B). Using multiple configurations ensures that the endpoint of one trajectory provides no information as to whether the subsequent trajectory will be the same or different. Another approach to eliminating position cues is to use random dot stimuli which have also been shown to give rise to a perceptual anisotropy (Gros et al., 1998). However, we used single spots so as to have the same stimuli for both perception and pursuit trials.

Trials used to estimate discriminability of pursuit eye movements began with 1000–1200 ms of fixation in the middle of the screen. The fixation point then disappeared, and a white target appeared 3° eccentrically to the right (0°), obliquely (45°), or up (90°) and immediately began moving at 25°/s toward or nearly toward the position of fixation. The target moved for 400–500 ms and then stopped and remained stationary for 500 ms. “Standard” trials provided target motion along cardinal or diagonal axes (0°, 45°, and 90°). “Test” trials provided target motion in directions slightly different from standard trials. The angle between standard and test target motion will be referred to as the “pursuit separation.” Trials were blocked according to the direction of the target motion. About 80 trials were in each block. Pursuit separations ranged from 2.5° to 6° depending on the subject. We attempted to match the directional separation used to estimate perceptual discriminability, but two subjects had to be tested at slightly larger pursuit separations (2.5° versus 3° for



subject RR and 1.5° versus 3.5° for subject MB). For smaller pursuit separations,  $D'$  was so small at every axis that a comparison across axes proved impractical. For larger perceptual separations, the task became so easy that subjects made no false alarms and a Z score could not be calculated. Subjects were additionally tested on one larger pursuit separation.

#### Estimation of Discriminability

To estimate perceptual discriminability, the percentages of hits and false alarms were used to compute Z scores.  $D'$  was estimated as the difference between hit and false alarm Z scores (Green and Swets, 1966). Responses to trajectories around base directions of 0°, 45°, and 90° were analyzed separately so that discriminability along each of the axes could be independently measured. On some early experiments, a staircase procedure was used to estimate thresholds for discriminability around each axis. Estimations of discriminability using thresholds and  $D'$  yielded similar anisotropies but we report the latter since  $D'$  was used for pursuit.

To estimate discriminability of pursuit eye movements, the first 90 ms (110–200 ms after the onset of target motion, dashed lines, Figure 3C) of the response was analyzed. This analysis interval (110–200 ms) was selected to approximately coincide with the initial open-loop period of smooth pursuit (Lisberger and Westbrook, 1985). Due to delays in visual processing, pursuit during this interval reflects visual stimuli that took place between about 0 and 90 ms after the onset of target motions. Trials were aligned to the onset of target motion, and any trials containing saccades during the analysis interval were excluded from subsequent analyses, leaving 45–60 trials for each stimulus condition.

Pursuit direction was computed for each of the nine 10 ms time bins in the analysis period for each standard and test trial. For trajectories near 0°, pursuit direction was computed by the following formula:

$$direction = \tan^{-1} \left( \frac{\dot{E}_V}{\dot{E}_H} \right) \quad (1)$$

where  $\dot{E}_V$  and  $\dot{E}_H$  are averages of vertical and horizontal eye velocity over each 10 ms bin. To avoid nonlinearities in the arctangent function, response trajectories near 45° or 90° were rotated so that each pair was centered near 0°, and direction was computed with Equation 2. The computed directions were then rotated back by the same amount. Responses during particular intervals are referred to by the time point in the center of that interval (i.e., the interval from 20–30 ms is referred to as 25 ms).

We estimated  $D'$  for pursuit along a particular axes from the distributions of pursuit directions in standard and test trials as

$$D' = \frac{R_s - R_t}{\sqrt{(\sigma_s^2 + \sigma_t^2)/2}} \quad (2)$$

where  $R_s$  and  $\sigma_s^2$  are the mean and variance of the response direction for standard (s) and test (t) target motion. The same measure was also used to estimate the discriminability expected by random fluctuations of eye velocity for Figure 3F (dashed trace). To estimate  $D'$  for this analysis, we randomly divided all the responses to a single trajectory of target motion into two groups. We then computed  $D'$  values for the two groups of responses to the same trajectory just as we computed  $D'$  values for two groups of responses to different trajectories.  $D'$  values for responses to the same trajectory would not be expected, on average, to differ very much from 0. Three  $D'$  values were computed for each subject using this bootstrapping method, generating a total of nine bootstrapped  $D'$  values which could then be compared to the nine true values of  $D'$ .

Since we divided the open-loop interval into nine time bins, nine values of  $D'$  could be calculated for each pair of trajectories. Three different analysis methods were used, each generating one value of  $D'$ . (1) We averaged the nine values of  $D'$  to give one mean estimate of the discriminability over time. This “equal-weighting” analysis takes into account all time points equally ensuring that time points of high discriminability were weighted the same as points of low discriminability. (2) We took the maximum value of  $D'$  as the estimate of discriminability for the whole trial. This “maximum-only” analysis represents the opposite extreme from the equal-weighting

analysis: a brief moment of high discriminability causes the whole response to have a large  $D'$  value. (3) We weighted each time point by a measure related to  $D'$ , the linear discriminant (Duda and Hart, 1973). The discriminant is defined as the difference between the mean values of the standard and test distributions at each time point. The dot product of each point and the discriminant was taken to project each point onto the discriminant. Thus the nine standard and nine test distributions were collapsed to one standard and one test distribution.  $D'$  was then calculated for these two new distributions. This analysis ensured that time points where standard and test responses were very different would be weighted more heavily than time points where standard and test responses were almost identical. However, unlike the maximum-only analysis, all points were taken into account.

#### Testing for an Anisotropy

When measuring both pursuit and perception, we took the data as evidence for an anisotropy if the values of  $D'$  varied systematically across different base target directions. To quantify the extent to which pursuit and perception show anisotropies based on whether the direction of target motion was cardinal (horizontal or vertical) or diagonal, we computed an anisotropy index as

$$AI = \frac{D'_{cardinal} - D'_{diagonal}}{D'_{cardinal} + D'_{diagonal}} \quad (3)$$

$D'_{cardinal}$  was obtained by averaging the  $D'$  values for horizontal and vertical target motion, which were never significantly different for either pursuit ( $p = 0.51, 0.15, 0.36$  for the equal-weighting, maximum-only, and discriminant estimates of  $D'$ ) or perception ( $p = 0.64$ ). The value of the index is positive when discriminability is higher along cardinal axes than diagonal axes, negative when the reverse is true, and zero when no anisotropy exists. Because error bars are not associated with values of  $D'$  or the anisotropy index, statistical analysis was performed across rather than within subjects.

#### Single-Unit Recording in Area MT

Single-unit recordings were made in area MT of 11 anesthetized, paralyzed macaque monkeys (*Macaca fascicularis*) as part of a different study (Priebe et al., 2002). Because the previous study was not designed specifically to measure anisotropies in area MT, the entire region may not always have been completely sampled. Details of the animal preparation and data acquisition were the same as previously reported (Priebe et al., 2002). All methods received prior approval by the Institutional Animal Care and Use Committee at University of California, San Francisco and were in compliance with the regulations of the Committee.

#### Stimulus Presentation

For each isolated neuron, a random dot stimulus containing 300 dots was displayed on an analog oscilloscope (Hewlett-Packard 1341B) that subtended 20° × 20°. An iterative procedure was used to position the display, choose the preferred speed of the neuron, and customize the size of a square window in the center of the dot field to be a size that caused the largest response in the neuron under study. At the beginning of each trial, the full dot field appeared and was stationary for 256 ms. Dots then moved coherently underneath the chosen window in the center of the dot field, in one of eight directions for 512 ms. Finally, motion stopped, and the dots remained visible for another 256 ms.

#### Estimate of Discriminability

To estimate preferred direction and tuning bandwidth, the response at each direction was taken as a vector where the length corresponded to the amplitude of the response, and the angle corresponded to motion direction. The vectors corresponding to all directions were summed. The angle of the resulting vector was taken as the preferred direction of the neuron. The length of the vector, called the “angular variance,” was taken as a measure of how narrowly the cell was tuned. The firing rate in the preferred direction, with the baseline subtracted off, was taken as the neuron’s peak firing rate.

To compute the fano factor (ratio of the variance to the mean),

the mean and variance of firing rates in each neuron's preferred direction were computed in a sliding 20 ms window (sliding at 1 ms) between 194 and 544 ms after the onset of stimulus motion (de Ruyter van Steveninck et al., 1997). These values were then averaged to yield one mean and one variance value for each trial.

To estimate the steepness of the direction tuning at particular polar positions, we fitted the averages of firing rate as a function of motion direction with a Gaussian function:

$$R(\theta) = d + ae^{-\frac{(\theta-b)^2}{2c^2}} \quad (4)$$

where  $a$  is the peak of the tuning curve,  $b$  is the preferred direction,  $c$  is the standard deviation, and  $d$  is the offset. The fitted curve then was numerically differentiated, and the slope was read off at the desired direction ( $\theta$ ).

To test whether distributions of responses were statistically different from random, Hotelling's  $T^2$  tests were used. We report the confidence interval (CI) for an ellipse containing the origin.

#### Acknowledgments

We are indebted to K.H. Britten and M.M. Churchland who provided feedback on earlier versions of the manuscript. S.G.L. is an investigator of the Howard Hughes Medical Institute. Research was supported by the Howard Hughes Medical Institute as well as the National Science Foundation (A.K.C. and J.L.G.).

Received: September 18, 2002

Revised: January 24, 2003

#### References

- Aggleton, J.P., and Mishkin, M. (1983). Visual recognition impairment following medial thalamic lesions in monkeys. *Neuropsychologia* 21, 189–197.
- Albright, T.D. (1984). Direction and orientation selectivity of neurons in visual area MT of the macaque. *J. Neurophysiol.* 52, 1106–1130.
- Ball, K., and Sekuler, R. (1980). Models of stimulus uncertainty in motion perception. *Psychol. Rev.* 87, 435–469.
- Beutter, B.R., and Stone, L.S. (1998). Human motion perception and smooth eye movements show similar directional biases for elongated apertures. *Vision Res.* 38, 1273–1286.
- Britten, K.H., Newsome, W.T., Shadlen, M.N., Celebrini, S., and Movshon, J.A. (1996). A relationship between behavioral choice and the visual responses of neurons in macaque MT. *Vis. Neurosci.* 13, 87–100.
- Bruno, N. (2001). When does action resist visual illusions? *Trends Cogn. Sci.* 5, 379–382.
- Burr, D.C., Morrone, M.C., and Ross, J. (2001). Separate visual representations for perception and action revealed by saccadic eye movements. *Curr. Biol.* 11, 798–802.
- Churchland, A.K., and Lisberger, S.G. (2002). Gain control in human smooth-pursuit eye movements. *J. Neurophysiol.* 87, 2936–2945.
- de Ruyter van Steveninck, R.R., Lewen, G.D., Strong, S.P., Koberle, R., and Bialek, W. (1997). Reproducibility and variability in neural spike trains. *Science* 275, 1805–1808.
- Duda, R.O., and Hart, P.E. (1973). *Pattern Classification and Scene Analysis* (New York: Wiley).
- Dyde, R.T., and Milner, A.D. (2002). Two illusions of perceived orientation: one fools all of the people some of the time; the other fools all of the people all of the time. *Exp. Brain Res.* 144, 518–527.
- Farah, M.J., Brunn, J.L., Wong, A.B., Wallace, M.A., and Carpenter, P.A. (1990). Frames of reference for allocating attention to space: evidence from the neglect syndrome. *Neuropsychologia* 28, 335–347.
- Felleman, D.J., and Van Essen, D.C. (1991). Distributed hierarchical processing in the primate cerebral cortex. *Cereb. Cortex* 1, 1–47.
- Franz, V.H. (2001). Action does not resist visual illusions. *Trends Cogn. Sci.* 5, 457–459.
- Goodale, M.A., and Milner, A.D. (1992). Separate visual pathways for perception and action. *Trends Neurosci.* 15, 20–25.
- Goodale, M.A., Milner, A.D., Jakobson, L.S., and Carey, D.P. (1991). A neurological dissociation between perceiving objects and grasping them. *Nature* 349, 154–156.
- Green, D.M., and Swets, J.A. (1966). *Signal Detection Theory and Psychophysics* (New York: Wiley).
- Gros, B.L., Blake, R., and Hiris, E. (1998). Anisotropies in visual motion perception: a fresh look. *J. Opt. Soc. Am. A Opt. Image Sci. Vis.* 15, 2003–2011.
- Hallett, P.E., and Lightstone, A.D. (1976). Saccadic eye movements towards stimuli triggered by prior saccades. *Vision Res.* 16, 99–106.
- Heeley, D.W., and Buchanan-Smith, H.M. (1992). Directional acuity for drifting plaids. *Vision Res.* 32, 97–104.
- Huk, A., Palmer, J., and Shadlen, M.N. (2002). Temporal integration of visual motion information: Evidence from response times. *Journal of Vision* 2, 228a.
- Ingle, D., Goodale, M.A., and Mansfield, R.J.W. (1982). *Analysis of Visual Behavior* (Cambridge, MA: MIT Press), pp. x, 834.
- Kaminski, H.J., and Leigh, R.J. (2002). *Neurobiology of Eye Movements: From Molecules to Behavior* (New York: New York Academy of Sciences).
- Keller, E.L., and Heinen, S.J. (1991). Generation of smooth-pursuit eye movements: neuronal mechanisms and pathways. *Neurosci. Res.* 11, 79–107.
- Kiorpes, L., Walton, P.J., O'Keefe, L.P., Movshon, J.A., and Lisberger, S.G. (1996). Effects of early-onset artificial strabismus on pursuit eye movements and on neuronal responses in area MT of macaque monkeys. *J. Neurosci.* 16, 6537–6553.
- Komatsu, H., and Wurtz, R.H. (1988). Relation of cortical areas MT and MST to pursuit eye movements. I. Localization and visual properties of neurons. *J. Neurophysiol.* 60, 580–603.
- Komatsu, H., and Wurtz, R.H. (1989). Modulation of pursuit eye movements by stimulation of cortical areas MT and MST. *J. Neurophysiol.* 62, 31–47.
- Kowler, E., and McKee, S.P. (1987). Sensitivity of smooth eye movement to small differences in target velocity. *Vision Res.* 27, 993–1015.
- Krauzlis, R.J., and Adler, S.A. (2001). Effects of directional expectations on motion perception and pursuit eye movements. *Vis. Neurosci.* 18, 365–376.
- Lisberger, S.G., and Westbrook, L.E. (1985). Properties of visual inputs that initiate horizontal smooth pursuit eye movements in monkeys. *J. Neurosci.* 5, 1662–1673.
- Lisberger, S.G., Evinger, C., Johanson, G.W., and Fuchs, A.F. (1981). Relationship between eye acceleration and retinal image velocity during foveal smooth pursuit in man and monkey. *J. Neurophysiol.* 46, 229–249.
- Lisberger, S.G., Morris, E.J., and Tychsen, L. (1987). Visual motion processing and sensory-motor integration for smooth pursuit eye movements. *Annu. Rev. Neurosci.* 10, 97–129.
- Macmillan, N.A., and Creelman, C.D. (1991). *Detection Theory: A User's Guide* (Cambridge, England; New York: Cambridge University Press).
- Maunsell, J.H., and Van Essen, D.C. (1983). Functional properties of neurons in middle temporal visual area of the macaque monkey. I. Selectivity for stimulus direction, speed, and orientation. *J. Neurophysiol.* 49, 1127–1147.
- Milner, A.D., Perrett, D.I., Johnston, R.S., Benson, P.J., Jordan, T.R., Heeley, D.W., Bettucci, D., Mortara, F., Mutani, R., Terazzi, E., et al. (1991). Perception and action in 'visual form agnosia'. *Brain* 114, 405–428.
- Morris, E.J., and Lisberger, S.G. (1987). Different responses to small visual errors during initiation and maintenance of smooth-pursuit eye movements in monkeys. *J. Neurophysiol.* 58, 1351–1369.
- Newsome, W.T., and Pare, E.B. (1988). A selective impairment of motion perception following lesions of the middle temporal visual area (MT). *J. Neurosci.* 8, 2201–2211.
- Newsome, W.T., Wurtz, R.H., Dursteler, M.R., and Mikami, A. (1985).

Deficits in visual motion processing following ibotenic acid lesions of the middle temporal visual area of the macaque monkey. *J. Neurosci.* *5*, 825–840.

Perenin, M.T., and Vighetto, A. (1988). Optic ataxia: a specific disruption in visuomotor mechanisms. I. Different aspects of the deficit in reaching for objects. *Brain* *111*, 643–674.

Priebe, N.J., Churchland, M.M., and Lisberger, S.G. (2002). Constraints on the source of short-term motion adaptation in macaque area MT. I. the role of input and intrinsic mechanisms. *J. Neurophysiol.* *88*, 354–369.

Salzman, C.D., Britten, K.H., and Newsome, W.T. (1990). Cortical microstimulation influences perceptual judgements of motion direction. *Nature* *346*, 174–177.

Salzman, C.D., Murasugi, C.M., Britten, K.H., and Newsome, W.T. (1992). Microstimulation in visual area MT: effects on direction discrimination performance. *J. Neurosci.* *12*, 2331–2355.

Watamaniuk, S.N., and Heinen, S.J. (1999). Human smooth pursuit direction discrimination. *Vision Res.* *39*, 59–70.

Weiskrantz, L., and Saunders, R.C. (1984). Impairments of visual object transforms in monkeys. *Brain* *107*, 1033–1072.

Zeki, S.M. (1978). Functional specialisation in the visual cortex of the rhesus monkey. *Nature* *274*, 423–428.